

# MANUFACTURING INDUSTRY



# Welcome To Our Company

Situated in Delhi, India, we, Reshmaa Engineering are a prime producer of high-grade Sanitizer Tunnel, Belt Conveyors, Mild Steel Laboratory Jaw Crusher, Mild Steel Jaw Stone Crusher, Green PVC Conveyor Belt, Black Rubber Conveyor Belt, etc. Manufactured by using modern techniques and machinery, our products have high performance, smooth operations, longer functional life and simple installation. In our modern production unit, all the goods are produced in compliance with the industry set norms & standards. Besides this, through different modes of transportation, we deliver the end products to the final destination of the clients. We share great relations with our valued customers who are associated with us for the past many years.



**E A. MALIK**  
DIRECTOR-TECH

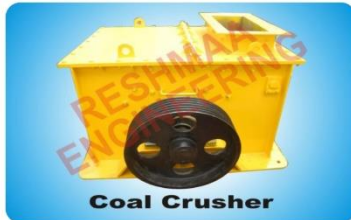
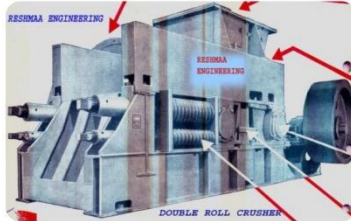
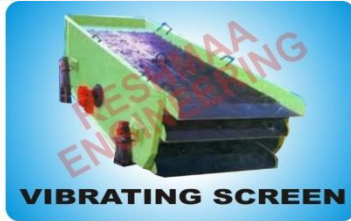

# We Are The Biggest Manufacturer Of Machines

We, Reshmaa Engineering, are an eminent manufacturer and supplier of industrial equipment, which is widely used in heavy duty industries. The organization takes full responsibility in producing quality products such as Plastic Modular Conveyor Belt, Mild Steel Stone Crusher, Mild Steel Single Toggle Jaw Crusher, Coal Crusher, Industrial Vibrating Screen, etc.

## *Detail :*

Which are in compliance with international standards. All these products exhibit striking features in terms of swift performance and smooth operational life, which meets varied requirements of clients. Moreover, we regularly update our business methodologies and believe in focusing on product development, giving modern day technology due consideration



# About Our Vision Statements



Subtitle Here

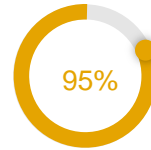

At the heart of Reshma Engineering's journey lies a powerful vision – to be a catalyst for transformative change in the world of precision engineering.

The company envisions a future where technological advancements and sustainable practices converge, creating a harmonious balance between innovation and environmental responsibility. This vision extends beyond the confines of the factory floor, aiming to inspire the entire industry towards greater efficiency, reduced environmental impact, and enhanced societal well-being.

## About Our Industrial's Mission Statements

Reshma Engineering's mission is intricately woven into the fabric of its operations. Every endeavor, every innovation, and every partnership is guided by a singular purpose – to deliver exceptional solutions while upholding the highest standards of quality and integrity.

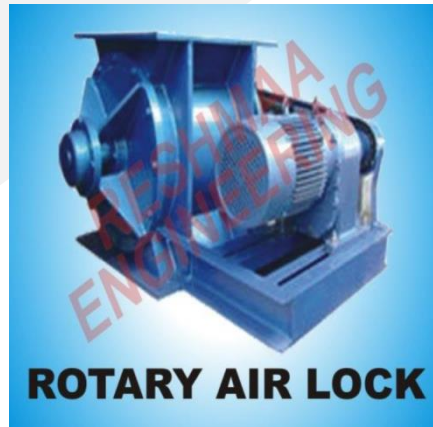
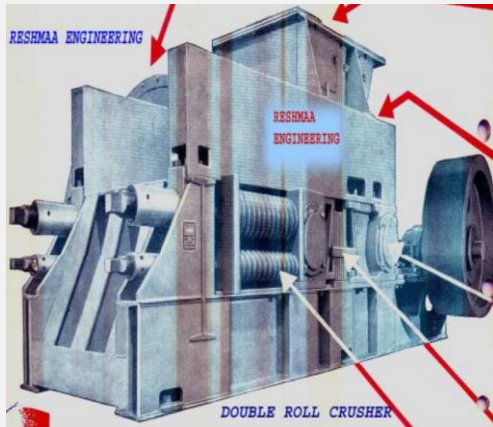

- 01 The company is driven by a relentless pursuit of excellence, aiming not just to meet client expectations but to exceed them. Through advanced fabrication techniques, state-of-the-art machining processes, and meticulous assembly methods
- 02 Reshma Engineering strives to optimize efficiency, enhance productivity, and elevate the performance of its clients' businesses.

# OUR PRODUCTS



## OUR FIELD OF EXPERTISE INCLUDES BUT IS NOT LIMITED TO

Coal handling systems

Crushing, screening, & powder grinding mill

Sand washing plant

P.O.P plants

Specialized crushing & powder grinding mill

## OUR RANGE OF EQUIPMENT INCLUDES

Powder grinding mill

coal crusher

Stone crusher

Single roll crusher

Ring crusher

Double roll crusher

Jew crusher

Impact coal crusher

Vibrating screen

Bucket elevator

Screw conveyor

Bag diverters

Air slides conveyor

Rotary air lock

Belt conveyors

Chain Conveyor

Washing plant

Sand crusher

Gypsum board recycling system

Spares and repairing component i.e. for above equipment & any kind off fabrication job.

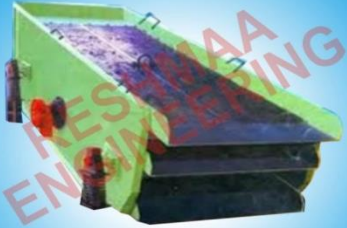

**VIBRATING SCREEN**



**SCREW CONVEYOR**



**Coal Crusher**

## LIST OF MACHINERY

LATHE

GEAR HOBGING

MILLING MACHINE

SHAPER

PRESS

SLOTING

CUTTING

BENDING ROLLING

DRILL MACHINE

WELDING MACHINE

GRINDER

HACKSAW

WIRE ROPE HOIST (3 Ton)

CHAIN PULLEY BLOCK

POLISHING & BUFFING

TESTING

PAINTING SPRAY MACHINE





# CHAIN CONVEYOR / DRACK CHAIN CONVEYOR

It's an alternative substance used in place of fiber. It is easier to maintain than the other two of our belts and we use it commonly on slippery drives to reduce slippery. It is a valuable choice for you if you are concerned about your product maintenance and frictions. It improves efficiency and safety in your business.

## **PRODUCT DETAILS**

**Usage :** Industrial

**Material :** Rubber

**Structure :** Belt

**Belt Conveyor :** Flat Belt

**Resistant Features :** Heat Resistant

**Supply Ability :** 500 Unit Per Month

## **PRODUCT SPECIFICATION**

**Resistant Features :** Heat Resistant

**Usage :** Industrial

**Material :** Rubber

**Structure :** Belt

**Belt Conveyor :** Flat Belt

## **TRADE INFORMATION**

**Payment Terms :** Cash Advance (CA)

**Delivery Time :** As Per Equipment

**Supply Ability :** 500 Unit Per Month

**Domestic And International**



# STONE CRUSHER PLANT

It is used to bear a heavy load of material or substance. It implies the full force onto the substance and reduces its size with our requirement. It is suitable for you if you want your material size reduction according to your need.

## PRODUCT DETAILS

**Condition:** New  
**Material :** Mild Steel  
**Computerized :** No  
**Automatic Grade :** Semi-Automatic  
**CNC Or Not :** Normal  
**Supply Ability :** 500 Unit Per Month

## PRODUCT SPECIFICATION

**Automatic Grade :** Semi-Automatic  
**Computerized :** No  
**Material :** Mild Steel  
**Condition :** New  
**CNC Or Not :** Normal

## TRADE INFORMATION

**Payment Terms :** Cash Advance (CA)  
**Delivery Time :** As Per Equipment  
**Supply Ability :** 500 Unit Per Month  
**Domestic And International**



# JAW STONE CRUSHER

The jaw stone crusher crushes the material when it is put into between its flywheels. Their heavy force instantly crushes the material to the maximum of our requirement at Once. When the gaps are closed the material is crushed and compressed at Once. It is specifically designed for you to compress your material operationally by you.

## PRODUCT DETAILS

**Condition:** New  
**Material :** Mild Steel  
**Computerized :** No  
**Automatic Grade :** Semi-Automatic  
**CNC Or Not :** Normal  
**Supply Ability :** 500 Unit Per Month

## PRODUCT SPECIFICATION

**Automatic Grade :** Semi-Automatic  
**Computerized :** No  
**Material :** Mild Steel  
**Condition :** New  
**CNC Or Not :** Normal

## TRADE INFORMATION

**Payment Terms :** Cash Advance (CA)  
**Delivery Time :** As Per Equipment  
**Supply Ability :** 500 Unit Per Month  
**Domestic And International**



# LABORATORY JAW CRUSHER

It is made to bear heavy loads of rocks or other substances. Its plates are made of higher resistance force material to crush heavy objects with ease. Its plates are made with objects resistance to force which can crush even the heaviest objects for you with ease. Ideal choice for you if you want to crush the heavy materials.

## PRODUCT DETAILS

**General Use:** Industrial  
**Material :** Stainless Steel  
**Computerized :** No  
**Automatic :** Yes  
**Feature :** High Efficiency  
**CNC Or Not :** Normal  
**Supply Ability :** 500 Unit Per Month

## PRODUCT SPECIFICATION

**Feature :** High Efficiency  
**Automatic :** Yes  
**Computerized :** No  
**Material :** Stainless Steel  
**General Use :** Industrial  
**CNC Or Not :** Normal

## TRADE INFORMATION

**Payment Terms :** Cash Advance (CA)  
**Delivery Time :** As Per Equipment  
**Supply Ability :** 500 Unit Per Month  
**Domestic And International**

# COAL GRINDING & CRUSHER MACHINE

Coal crushers are used to reduce the size of coal. They are designed in a way that they can bear both heavy and soft coals to crush with ease of impact. Various coal crushers depend on our size requirements and also the actual size or the coal. The crushers are chosen according to their capacity to bear the crush of materials. It is created by considering special coal characteristics which can easily and safely crush materials for you. For materials like coal it is vital for you.

## **PRODUCT DETAILS**

**Usage:** Industrial  
**Condition :** New  
**Material :** Stainless Steel  
**Power Source :** Electric  
**Supply Ability :** 500 Unit Per Month

## **PRODUCT SPECIFICATION**

**Usage:** Industrial  
**Condition :** New  
**Material :** Stainless Steel  
**Power Source :** Electric

## **TRADE INFORMATION**

**Payment Terms :** Cash Advance (CA)  
**Delivery Time :** As Per Equipment  
**Supply Ability :** 500 Unit Per Month  
**Domestic And International**



### **PRODUCT DETAILS**

**Usage:** Industrial

**Condition :** New

**Material :** Stainless Steel

**Power Source :** Electric

**Supply Ability :** 500 Unit Per Month

# VIBRATING SCREENS

They are the most common screen in every industry. It uses screens or mesh to separate the combined materials according to their density and their size as well. A high-frequency screen is used to it. It is commonly used by mining and recycling industries. It is generated by unbalanced mass and runs on the motor. It improves the product handling challenges and makes it easier to separate two objects from each other

### **PRODUCT SPECIFICATION**

**Usage:** Industrial

**Condition :** New

**Material :** Stainless Steel

**Power Source :** Electric

### **TRADE INFORMATION**

**Payment Terms :** Cash Advance (CA)

**Delivery Time :** As Per Equipment

**Supply Ability :** 500 Unit Per Month

**Domestic And International**

# COAL CRUSHER PLANT

It is like an all-in-one crushing machine. It works for almost every type of crushing whether is rock crushing, garbage crushing or other substances. These plants are both fixed and mobile with three different stations where crushing, selection and transporting services are done. This comprehensive make this plant a very valuable asset for material processing tasks.

## **PRODUCT DETAILS**

**Material :** Stainless Steel

**Computerized:** No

**Automatic Grade :** Semi-Automatic

**Power Source :** Electric

**Supply Ability :** 500 Unit Per Month

## **PRODUCT SPECIFICATION**

**Material :** Stainless Steel

**Computerized:** No

**Automatic Grade :** Semi-Automatic

**Power Source :** Electric

## **TRADE INFORMATION**

**Payment Terms :** Cash Advance (CA)

**Delivery Time :** As Per Equipment

**Supply Ability :** 500 Unit Per Month

**Domestic And International**

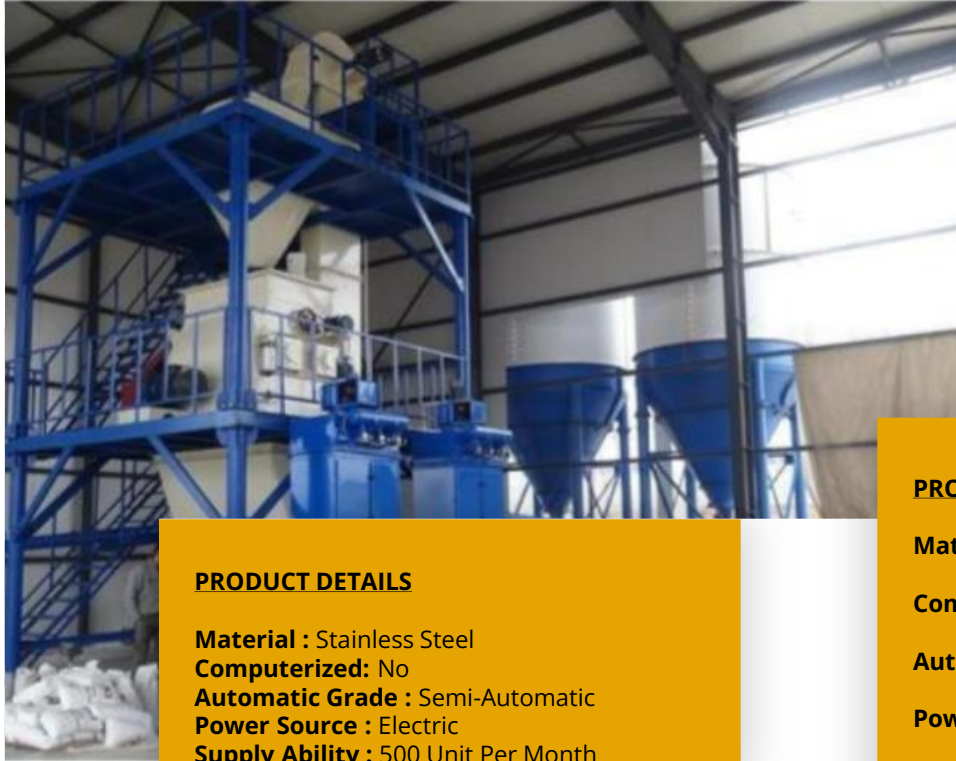

# PLASTER OF PARIS PLANT

Pop plant is used to create pop in larger amounts which is used to give fresh coats to walls, and properly structure them. It gets hardened up quickly and is used by almost every industry to receive a quality and fast result whether it's medical industry, construction industry or art, it is the most reliable plant for you.

## **PRODUCT DETAILS**

**Material :** Stainless Steel  
**Computerized:** No  
**Automatic Grade :** Semi-Automatic  
**Power Source :** Electric  
**Supply Ability :** 500 Unit Per Month

## **PRODUCT SPECIFICATION**

**Material :** Stainless Steel  
**Computerized:** No  
**Automatic Grade :** Semi-Automatic  
**Power Source :** Electric

## **TRADE INFORMATION**

**Payment Terms :** Cash Advance (CA)  
**Delivery Time :** As Per Equipment  
**Supply Ability :** 500 Unit Per Month  
**Domestic And International**



# ROLL CRUSHER



It involves individual particles nipped off between the roller surfaces. It is commonly used for size reductions. Coal, salt, limestone, bauxite and other similar substances are crushed with it to gain the size. It is used by mining and power generation industries too commonly today. It's efficiency has made itself the most common practice done by industries by enabling the precise control of sizes to meet your requirements.

## PRODUCT DETAILS

**Usage :** Industrial  
**Material :** Stainless Steel  
**Condition:** New  
**Power Source :** Electric  
**Supply Ability :** 500 Unit Per Month

## PRODUCT SPECIFICATION

**Usage :** Industrial  
**Material :** Stainless Steel  
**Condition:** New  
**Power Source :** Electric

## TRADE INFORMATION

**Payment Terms :** Cash Advance (CA)  
**Delivery Time :** As Per Equipment  
**Supply Ability :** 500 Unit Per Month  
**Domestic And International**

# SCREW CONVEYOR AND FEEDER

It is made to handle bulk solid materials where the flighter turn inside the hopper moving material forward and backwards. The ability to move materials in both directions is a valuable feature, as it ensures that materials are effectively transported and processed as needed.



## **PRODUCT DETAILS**

**Usage :** Industrial

**Material :** Stainless Steel

**Structure:** Belt

**Belt Conveyor :** Flat Belt

**Resistant :** Heat Resistant

**Supply Ability :** 500 Unit Per Month

## **PRODUCT SPECIFICATION**

**Usage :** Industrial

**Material :** Stainless Steel

**Structure:** Belt

**Belt Conveyor :** Flat Belt

**Resistant :** Heat Resistant

## **TRADE INFORMATION**

**Payment Terms :** Cash Advance (CA)

**Delivery Time :** As Per Equipment

**Supply Ability :** 500 Unit Per Month

**Domestic And International**

# PIPE ROLLERS



It is designed to ease the problems of plastic during the installation and jointing process. It reduces the chances of pipes being damaged. They are used for soil compaction processes for various types of soils. They basically level out the soil making it a versatile equipment for variety of services such as construction.

## **PRODUCT DETAILS**

**Usage :** Industrial

**Material :** Stainless Steel

**Feature :** High Quality

**Supply Ability :** 500 Unit Per Month

## **PRODUCT SPECIFICATION**

**Usage :** Industrial

**Material :** Stainless Steel

**Feature :** High Quality

## **TRADE INFORMATION**

**Payment Terms :** Cash Advance (CA)

**Delivery Time :** As Per Equipment

**Supply Ability :** 500 Unit Per Month

**Domestic And International**



### **PRODUCT DETAILS**

**Usage :** Industrial

**Material :** Stainless Steel

**Structure :** Belt

**Belt Conveyor :** Flat Belt

**Resistant Feature :** Heat Resistant

**Supply Ability :** 500 Unit Per Month

# BELT CONVEYOR

They are referred as drums or pulleys. It works as a loop belt around pulleys. It is an important part of industrial processes. It is supported by metal-plated beds or rollers placed upon conveyors upon which belts rest. This combination of pulleys is important part in handling wide range of products. It conveys more smooth and convenient material transportation to you.

### **PRODUCT SPECIFICATION**

**Usage :** Industrial

**Material :** Stainless Steel

**Structure :** Belt

**Belt Conveyor :** Flat Belt

**Resistant Feature :** Heat Resistant

### **TRADE INFORMATION**

**Payment Terms :** Cash Advance (CA)

**Delivery Time :** As Per Equipment

**Supply Ability :** 500 Unit Per Month

**Domestic And International**

# ELECTROMECHANICAL VIBRATORY FEEDER

Electromechanical vibratory feeders are mechanical devices that use vibration to convey bulk materials from storage bins or hoppers to processing machines or other conveyors. They are commonly used in a variety of industries, including food processing, pharmaceutical, chemical, and mining.

## **PRODUCT DETAILS**

**Usage :** Food Industry, Chemical, etc  
**Material :** Stainless Steel  
**Feature :** High Quality  
**Supply Ability :** 500 Unit Per Month

## **PRODUCT SPECIFICATION**

**Usage :** Food Industry, Chemical, etc  
**Material :** Stainless Steel  
**Feature :** High Quality

## **TRADE INFORMATION**

**Payment Terms :** Cash Advance (CA)  
**Delivery Time :** As Per Equipment  
**Supply Ability :** 500 Unit Per Month  
**Domestic And International**



# COAL CRUSHER RING TYPE

A coal crusher ring is a component of a coal crusher that is responsible for breaking down large pieces of coal into smaller, more manageable pieces. Crusher rings are typically made from high-strength materials, such as manganese steel or tungsten carbide, to withstand the wear and tear of the crushing process. They are designed to rotate at high speeds, shattering the coal against the walls of the crusher chamber.

## **PRODUCT DETAILS**

**Automation Grade:** Manual  
**Capacity:** Standard  
**Supply Ability :** 500 Unit Per Month

## **PRODUCT SPECIFICATION**

**Usage :** Industrial  
**Material :** Stainless Steel  
**Feature :** High Quality

## **TRADE INFORMATION**

**Payment Terms :** Cash Advance (CA)  
**Delivery Time :** As Per Equipment  
**Supply Ability :** 500 Unit Per Month  
**Domestic And International**



# WALL PUTTY MACHINE

A wall putty machine is a versatile tool used in the construction industry to mix and apply wall putty, a smooth paste-like substance used to level and smoothen walls before painting. These machines are designed to efficiently blend various ingredients, including cement, gypsum, and water,

## **PRODUCT DETAILS**

**Usage :** Wall Putty Spray

**Automatic :** Yes

**Feature :** High Quality

**Supply Ability :** 500 Unit Per Month

## **PRODUCT SPECIFICATION**

**Usage :** Wall Putty Spray

**Automatic :** Yes

**Feature :** High Quality

## **TRADE INFORMATION**

**Payment Terms :** Cash Advance (CA)

**Delivery Time :** As Per Equipment

**Supply Ability :** 500 Unit Per Month

**Domestic And International**



### **PRODUCT DETAILS**

**Low Frequency:** 1 Hz

**Measurement Range:** 200N, 25mV/N

**Hammer Length:** 250 mm

**Resolution:** 6 mNrms

# IMPACT HAMMER CRUSHER

An impact hammer is a mechanical device used to excite a structure and measure its dynamic response. It is commonly used in modal analysis, where it is used to identify the natural frequencies and damping ratios of a structure. Impact hammers are also used in structural health monitoring, where they are used to detect damage in a structure.

### **PRODUCT SPECIFICATION**

**Measurement Range:** 200N, 25mV/N

**Hammer Length:** 250 mm

**Resolution:** 6 mNrms

**Types:** Soft, Medium, Hard, Aluminum

### **TRADE INFORMATION**

**Payment Terms :** Cash Advance (CA)

**Delivery Time :** As Per Equipment

**Supply Ability :** 500 Unit Per Month

**Domestic And International**



# BAG DIVERTER



A coal crusher ring is a component of a coal crusher that is responsible for breaking down large pieces of coal into smaller, more manageable pieces. Crusher rings are typically made from high-strength materials, such as manganese steel or tungsten carbide, to withstand the wear and tear of the crushing process. They are designed to rotate at high speeds, shattering the coal against the walls of the crusher chamber.

## **PRODUCT DETAILS**

**Condition:** New  
**Lifting Capacity:** 1000 Kilograms (kg)  
**Power Source :** Electric  
**Voltage:** 110 AC  
**Feature:** Innovative Design

## **PRODUCT SPECIFICATION**

**Power Source :** Electric

**Voltage:** 110 AC

**Feature:** Innovative Design

**Attributes:** Strong, Easy To Operate

**Main Domestic Market:** All India

**Packaging Details :** Carton Box.

## **TRADE INFORMATION**

**Payment Terms :** Cash Advance (CA)

**Delivery Time :** As Per Equipment

**Supply Ability :** 500 Unit Per Month

**Domestic And International**

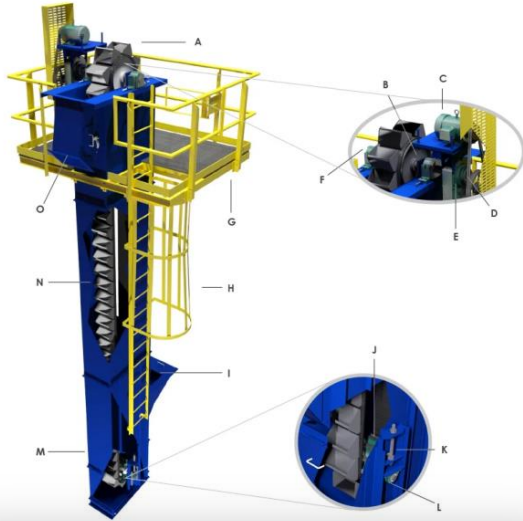

### **PRODUCT DETAILS**

**Capacity :** 1-2 ton

**Structure :** Bucket Elevator

**Brand :** Reshma Engineering

**Warranty:** 12 Months

# ENCLOSED BUCKET ELEVATOR

Enclosed bucket elevators are a type of conveyor that uses buckets attached to a continuous chain or belt to elevate material vertically. They are a common and efficient way to transport a wide variety of materials, including grains, seeds, powders, and pellets.

### **PRODUCT SPECIFICATION**

**Brand :** Reshmaa Engineering

**Warranty:** 12 Months

**Automation Grade:** Semi- Automatic

**Main Domestic Market:** All India

**Material :** Mild Steel

### **TRADE INFORMATION**

**Payment Terms :** Cash Advance (CA)

**Delivery Time :** As Per Equipment

**Supply Ability :** 500 Unit Per Month

**Domestic And International**



## ROTARY AIR LOCK

### PRODUCT DETAILS

**Design Type :** Raw

**Size :** 4-16inch

**Material :** Cast Iron / Fabricated

**Casing:** CI Casting

**Motor Power :** As Per Requirement

# ROTARY AIR LOCK

A rotary airlock, also known as a rotary feeder, rotary valve, or just rotary airlock, is a device used to control the flow of dry, free-flowing materials in pneumatic conveying systems. It serves as a "lock" to prevent air loss while simultaneously performing vital material handling functions. Rotary airlocks are commonly used in industries like food processing, pharmaceutical, chemical, and mining.

### PRODUCT SPECIFICATION

**Motor Speed :** 40

**Temperature :** 300 Degree

**Voltage:** 415 v

**Usage :** Boiler / Bag Filter

### TRADE INFORMATION

**Payment Terms :** Cash Advance (CA)

**Delivery Time :** As Per Equipment

**Supply Ability :** 500 Unit Per Month

**Domestic And International**



### **PRODUCT DETAILS**

**Supply Ability :** 500 Unit Per Month

# **FULL BODY SPRAY SANITIZER TUNNEL**

With our vast industry experience and competent workforce, we provide Full Body Spray Sanitizer Tunnel. This tunnel sprays a mist of sodium hypochlorite solution. Full Body Spray Sanitizer Tunnel is available in different specifications as per the application requirements of customers. This tunnel is required all public places where full human body sanitization is required.

### **TRADE INFORMATION**

**Payment Terms :** Cash Advance (CA)

**Delivery Time :** As Per Equipment

**Supply Ability :** 500 Unit Per Month

**Domestic And International**



# RESHMAA ENGINEERING



## Offices Location

G-3, GROUND FLOOR, 45C, AMAR  
PLAZA, HASSANPUR,  
I.P.EXTENSION. DELHI – 110092,

## Phone Number

+91 98716 37116

[www.crushingmaterial.com](http://www.crushingmaterial.com)

## Office Hours

Monday – Sunday  
09.00 AM – 11.00 PM

## E-mail Address

[Reshma.crushwheel@gmail.com](mailto:Reshma.crushwheel@gmail.com)  
[Crushingmaterial@gmail.com](mailto:Crushingmaterial@gmail.com)  
[ea.malik86@gmail.com](mailto:ea.malik86@gmail.com)

## Get In Touch

We have built a state-of-the-art infrastructure setup, which enables us to hold the business with perfection and execute each job in a hassle-free way, maintaining the time constraint. Spread over a large area, our production unit allows us to produce world-class Mild Steel Single Toggle Jaw Crusher, Coal Crusher, Plastic Modular Conveyor Belt, Mild Steel Stone Crusher, Industrial Vibrating Screen, etc.

# THANK YOU FOR WATCHING

Our unit is well connected to major transportation routes and comprises advanced machinery. This backs us to meet bulk order of consignments without any type of hassle. Moreover, all the crucial sections of quality, engineering, warehouse and packaging are maintained and handled by a team of experienced professionals.